

## 1 Features and functions

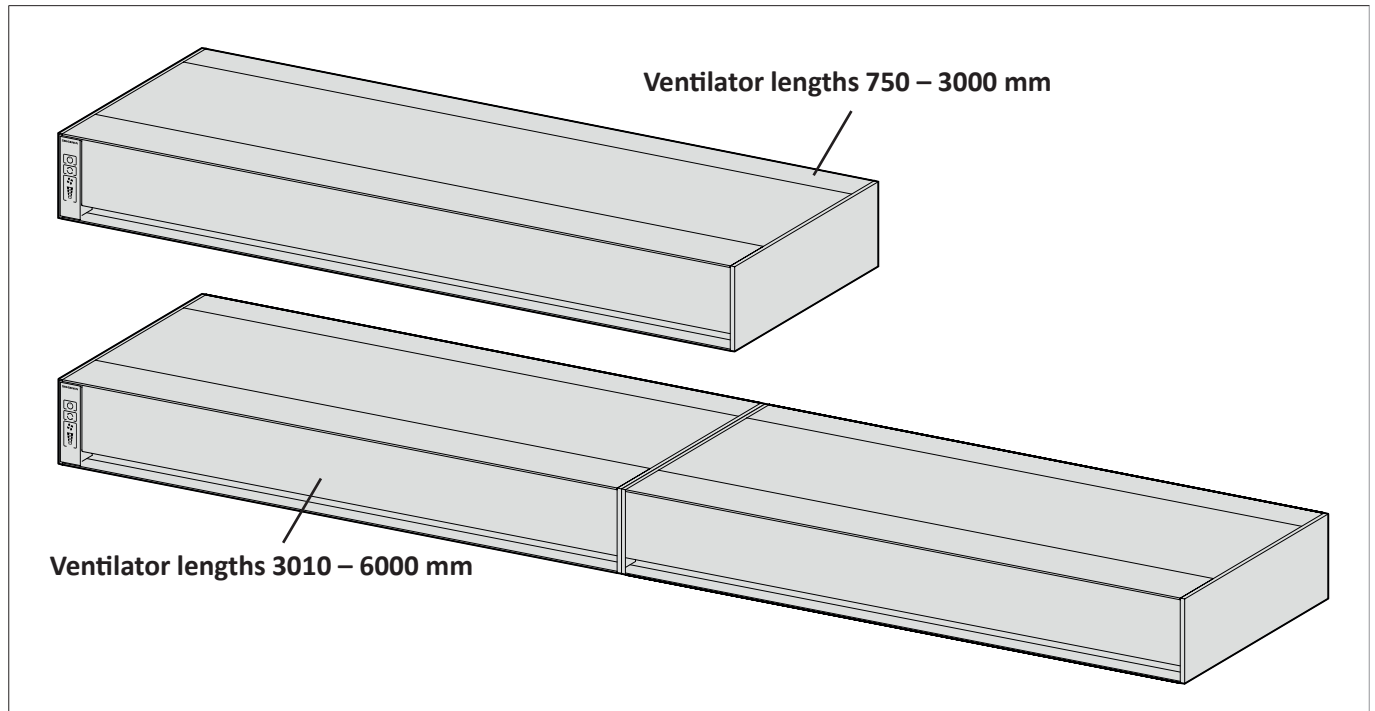

### 1.1 Features

- AEROMAT VT A is a unidirectional exhaust air ventilation unit in home ventilation systems for the ventilation of closed rooms. The exchange of air is accomplished using an exhaust air blower.
- AEROMAT VT A is available in 2 versions (special solutions on request):
  - AEROMAT VT A1 = 1 exhaust air blower
  - AEROMAT VT A2 = 2 exhaust air blower
- AEROMAT VT A is part of the AEROMAT VT systems, which consists of different device types. These different device types can be combined with each other. Separate data sheets must be taken into consideration.
- Installation variants:
  - reveal
  - reveal concealed (with vent duct)
  - lintel
  - lintel concealed (with lintel duct)
  - wall
  - concealed in the wall (with wall duct)

### 1.2 Functions

Versions	
Exhaust air filter ISO Coarse $\geq 30\%$	<input type="radio"/>
Locking plug (room side)	<input checked="" type="radio"/>
Electric lock	<input type="radio"/>
Touch control	<input checked="" type="radio"/>
Inside temperature and humidity sensor	<input checked="" type="radio"/>
Air quality sensor with CO <sub>2</sub> regulation	<input type="radio"/>
Air quality sensor with CO <sub>2</sub> and TVOC regulation	<input type="radio"/>
Wifi	<input type="radio"/>
Halogen-free cable	<input type="radio"/>
Digital outputs	<input type="radio"/>
External inputs (e. g night or cross ventilation or bathroom control)	<input type="radio"/>
Configurable software	<input type="radio"/>
SI-BUS	<input type="radio"/>

- *Serial version*
- *optional or alternative version*

## 2 Dimensions

### 2.1 Dimensions AEROMAT VT A

#### Units with standard cables

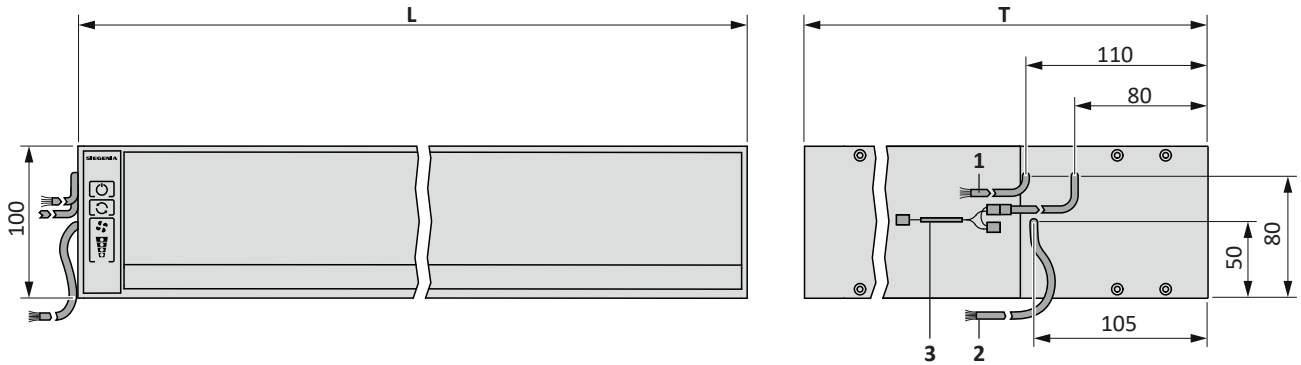

Measurements in mm

<b>L</b>	Ventilator length	Can be ordered in 10 mm increments
<b>T</b>	Ventilator depth	Can be ordered in 1 mm increments
<b>1</b>	Control cable 5 x 0.75 mm <sup>2</sup> for digital outputs	optional
<b>2</b>	Control cable 7 x 0.75 mm <sup>2</sup> for supply voltage	
<b>3</b>	SI-BUS cable with Y-cable	optional

#### Units with halogen-free cables

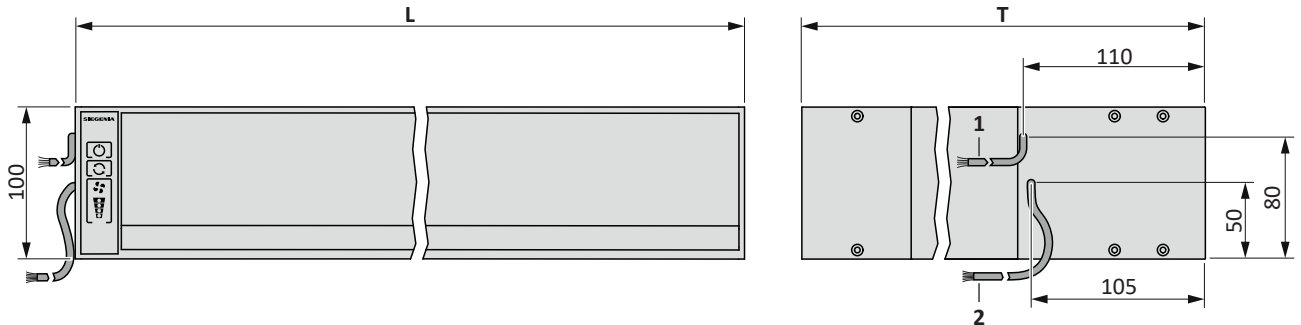

Measurements in mm

<b>L</b>	Ventilator length	Can be ordered in 10 mm increments
<b>T</b>	Ventilator depth	Can be ordered in 1 mm increments
<b>1</b>	Control cable 2 x 1.5 mm <sup>2</sup> for supply voltage	
<b>2</b>	Control cable 7 x 0.75 mm <sup>2</sup> for external outputs	

Device type	Dimension L (mm)	Dimension D (mm)
AEROMAT VT A1	750 – 6000	300 – 500
AEROMAT VT A2	1500 – 6000	300 – 500

## 2.2 Dimensions of outer panel without extension parts

The dimensions of the outside panels are dependent on the device equipment level and the ventilator length. You can find more detailed information about the outside panels in the media centre or via the following link:

[link.si/td/fens021/1024](https://link.si/td/fens021/1024)

Outer panel for horizontal installation

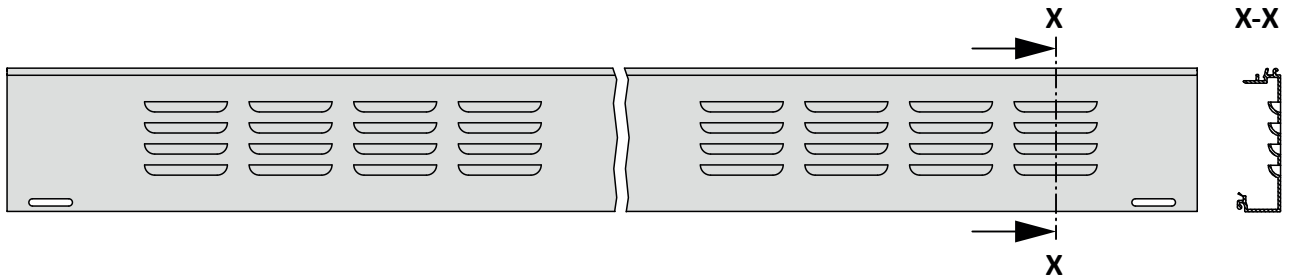

Outer panel for vertical installation

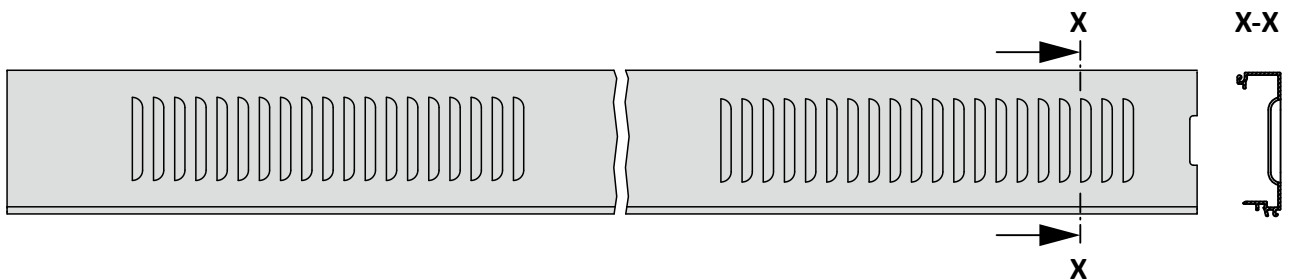

Outer panel for shadow gap

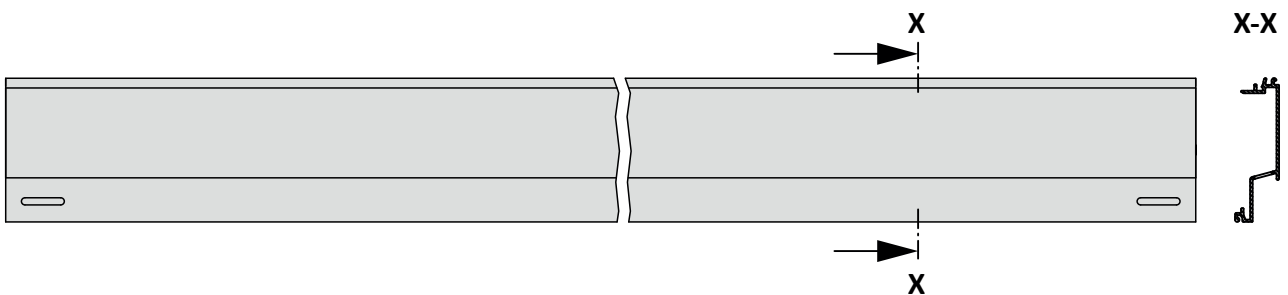

**2.3 Dimensions of reveal and lintel duct EPP**

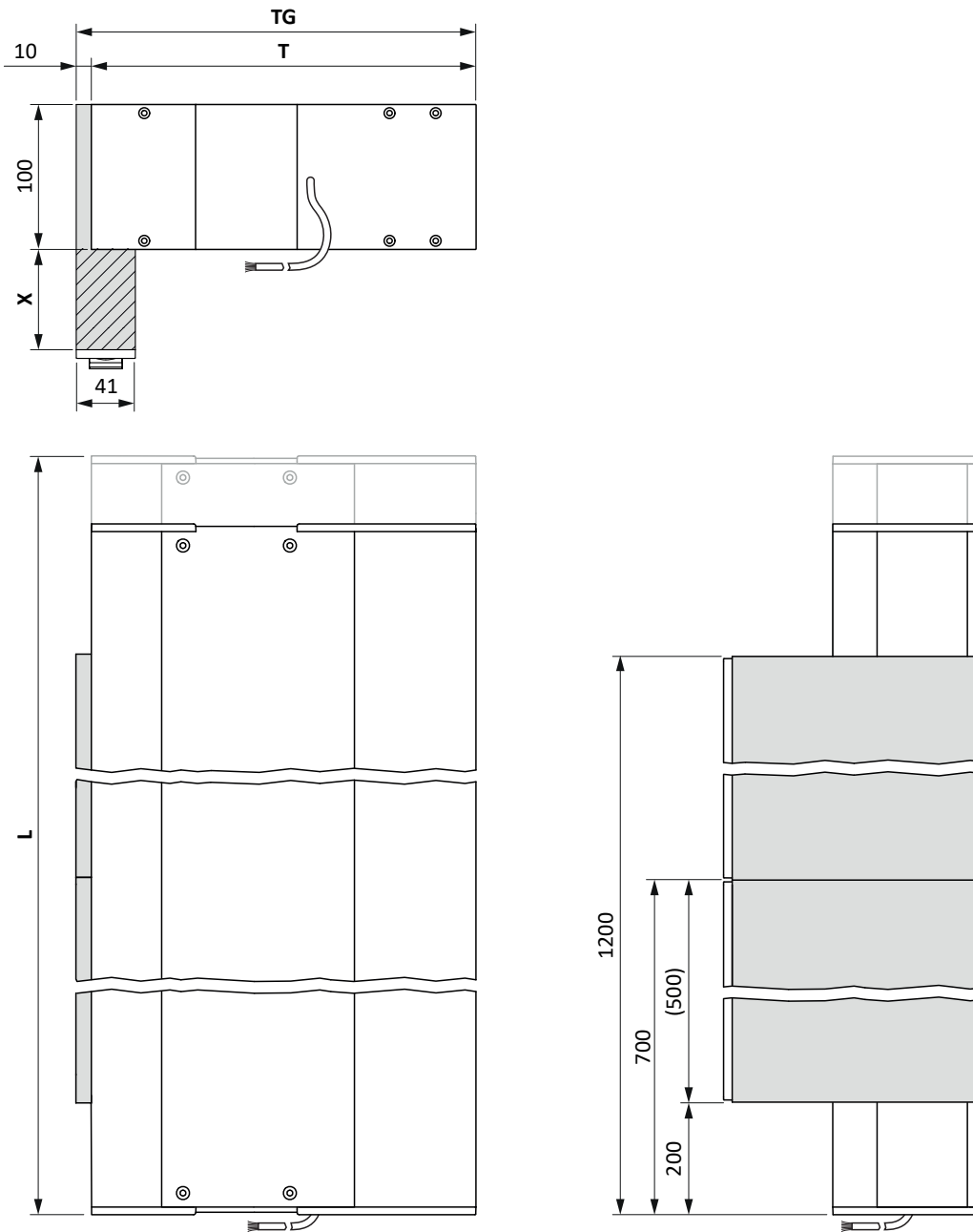

Measurements in mm

<b>L</b>	Ventilator length	Can be ordered in 10 mm increments
<b>T</b>	Ventilator depth	Can be ordered in 1 mm increments
<b>TG</b>	Total depth	Ventilator depth <b>T</b> + 10 mm
<b>X</b>	Height of ducts	The height of the ducts can be expanded by duct extensions (see accessories) in 100 mm increments. The ducts can be cropped on site to the final dimension (min. 25 mm).
	Cropping area	

Device type	Dimension L (mm)	Dimension D (mm)	Dimension X (mm)	Number of ducts
AEROMAT VT A1	750 – 6000	300 – 500	0 – 570	1
AEROMAT VT A2	1500 – 6000	300 – 500	0 – 570	2

## 2.4 Dimensions of reveal and lintel duct outside panels EPP

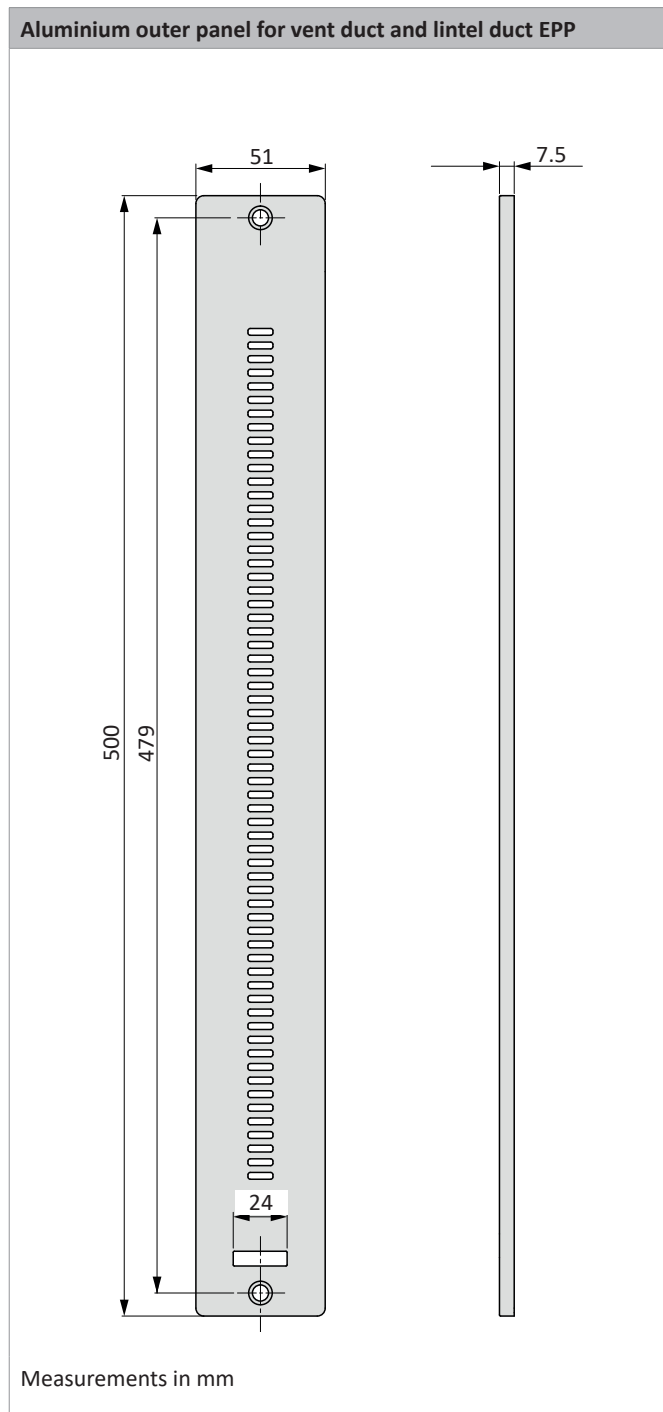
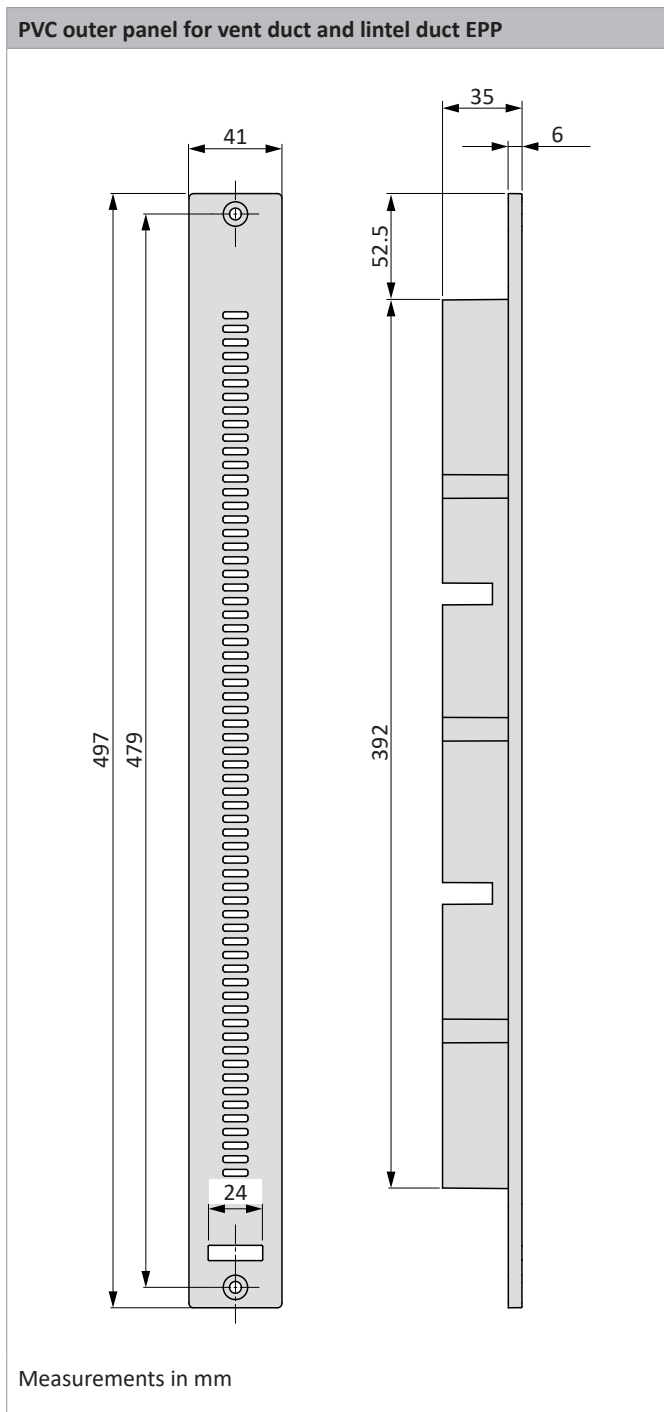

**2.5 Dimensions of wall duct EPP**

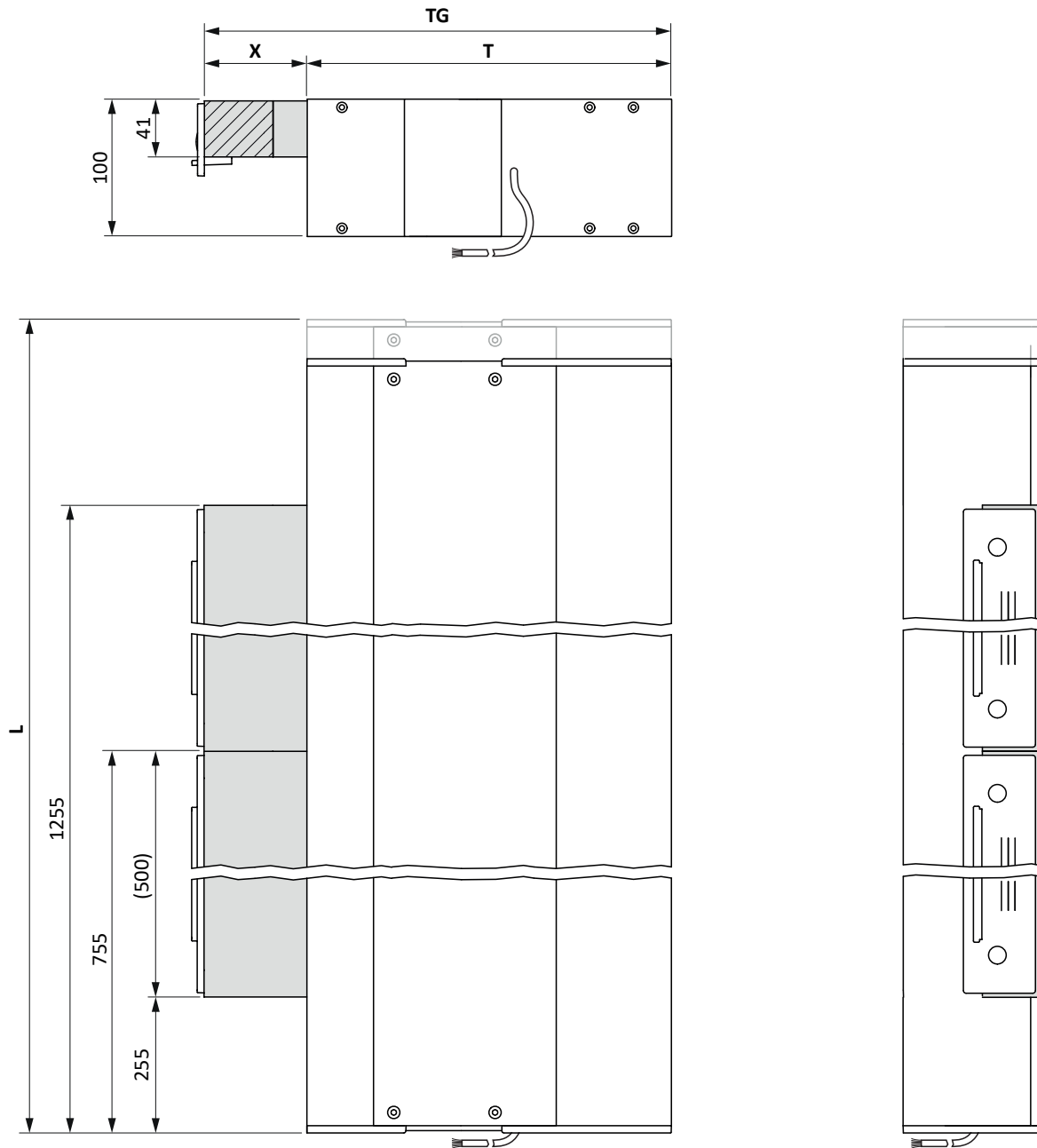

Measurements in mm

<b>L</b>	Ventilator length	Can be ordered in 10 mm increments
<b>T</b>	Ventilator depth	Can be ordered in 1 mm increments
<b>TG</b>	Total depth	Ventilator depth <b>T</b> + depth of ducts <b>X</b>
<b>X</b>	Depth of ducts	The depth of the ducts can be extended by duct extensions (see accessories) in 100 mm increments. The ducts can be cropped on site to the final dimension (min. 25 mm).
	Cropping area	

Device type	Dimension L (mm)	Dimension D (mm)	Dimension X (mm)	Number of ducts
AEROMAT VT A1	750 – 6000	300 – 500	25 – 500	1
AEROMAT VT A2	1500 – 6000	300 – 500	25 – 500	2

## 2.6 Dimensions of wall duct outside panels EPP

### Wall outer panel EPP

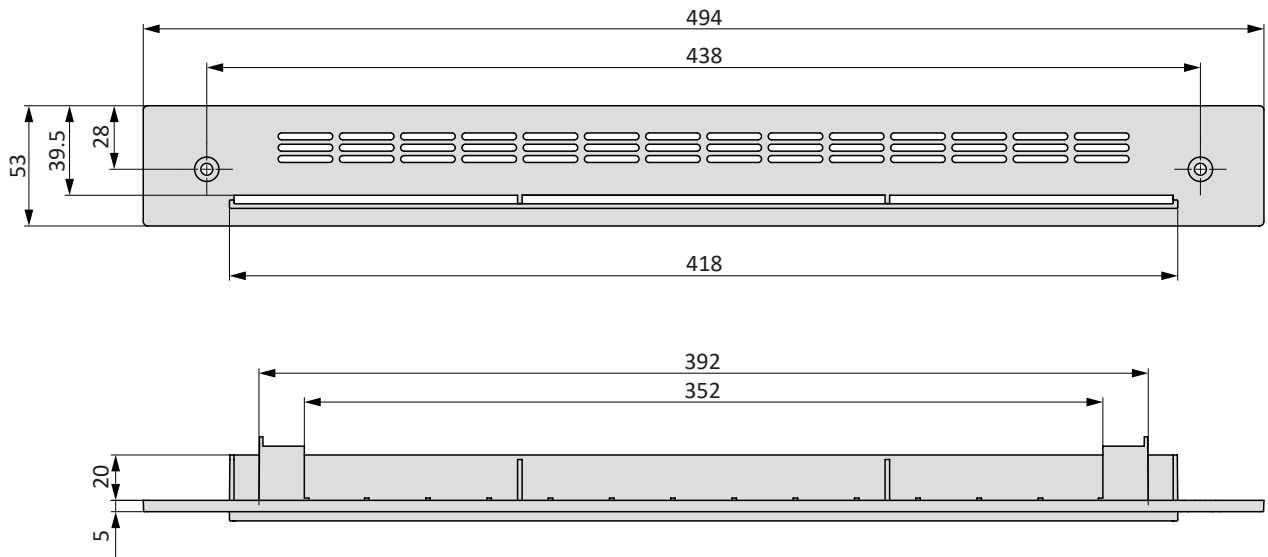

Measurements in mm

### Wall aluminium panel EPP

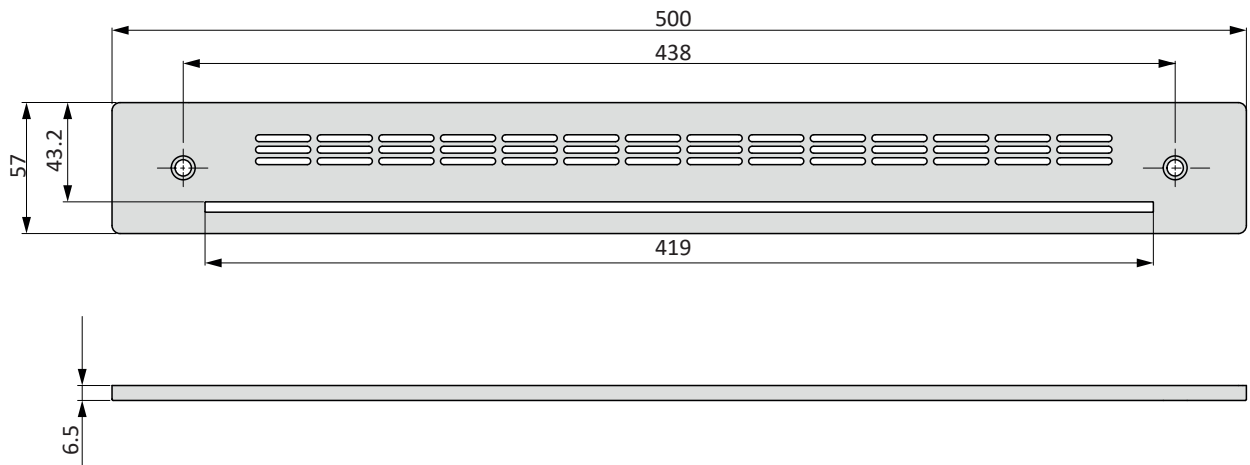

Measurements in mm

2.7 Dimensions of aluminium reveal and lintel duct

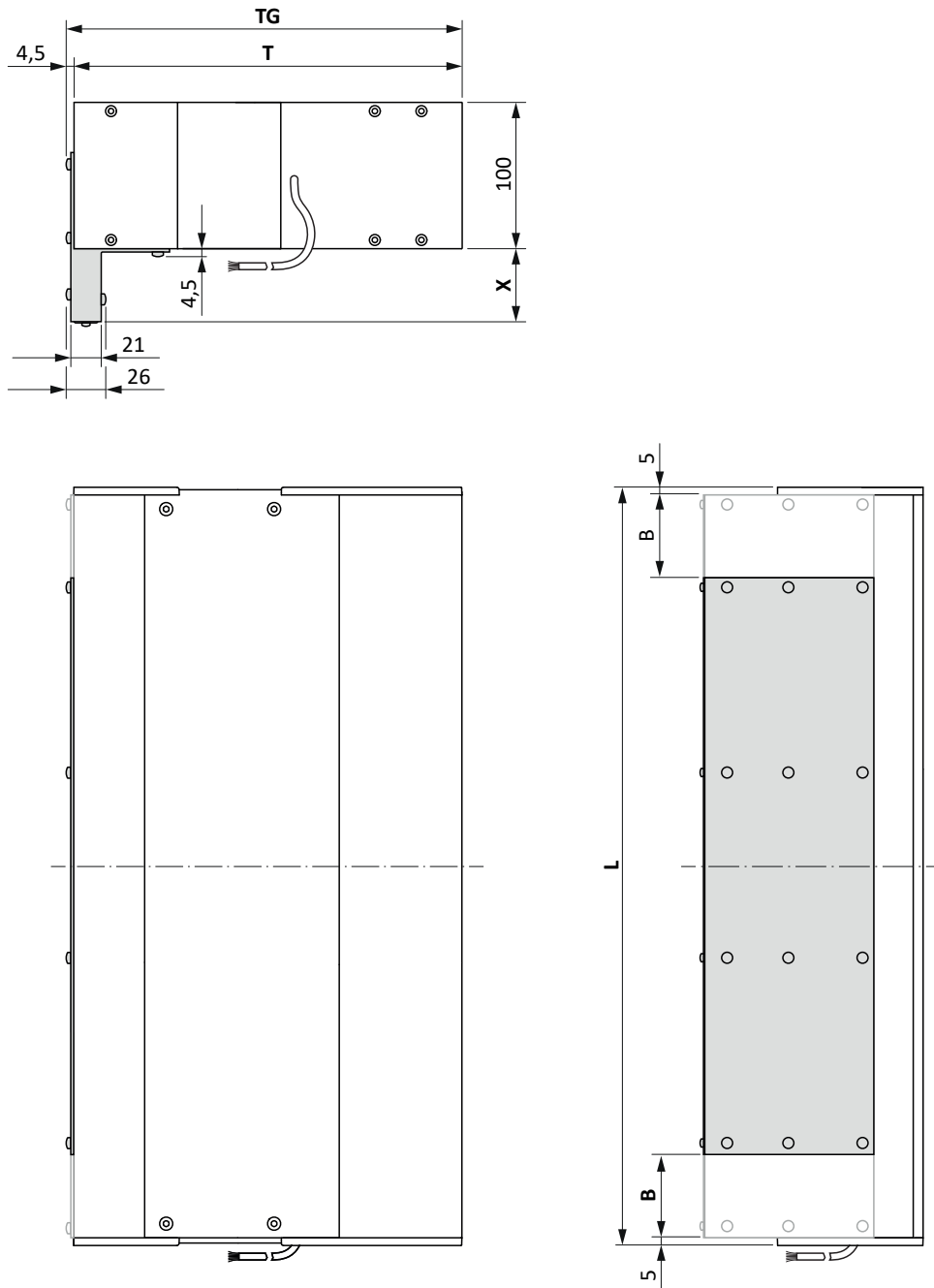

Measurements in mm

<b>B</b>	Dimension for indented duct	Can be ordered in 1 mm increments
<b>L</b>	Ventilator length	Can be ordered in 10 mm increments
<b>T</b>	Ventilator depth	Can be ordered in 1 mm increments
<b>TG</b>	Total depth	Ventilator depth <b>T</b> + 4.5 mm
<b>X</b>	Height of duct	Can be ordered in 1 mm increments



Device type	Dimension L (mm)	Dimension D (mm)	Dimension X (mm)	Dimension B (mm)
A1	750 – 890	300 – 500	25 – 1100	0 – 65
	900 – 3000			0 – 145
	3010 – 6000			0
A2	1500 – 3000	300 – 500	25 – 1100	0 – 145
	3010 – 6000			0

**2.8 Dimensions of aluminium reveal and lintel duct angled**

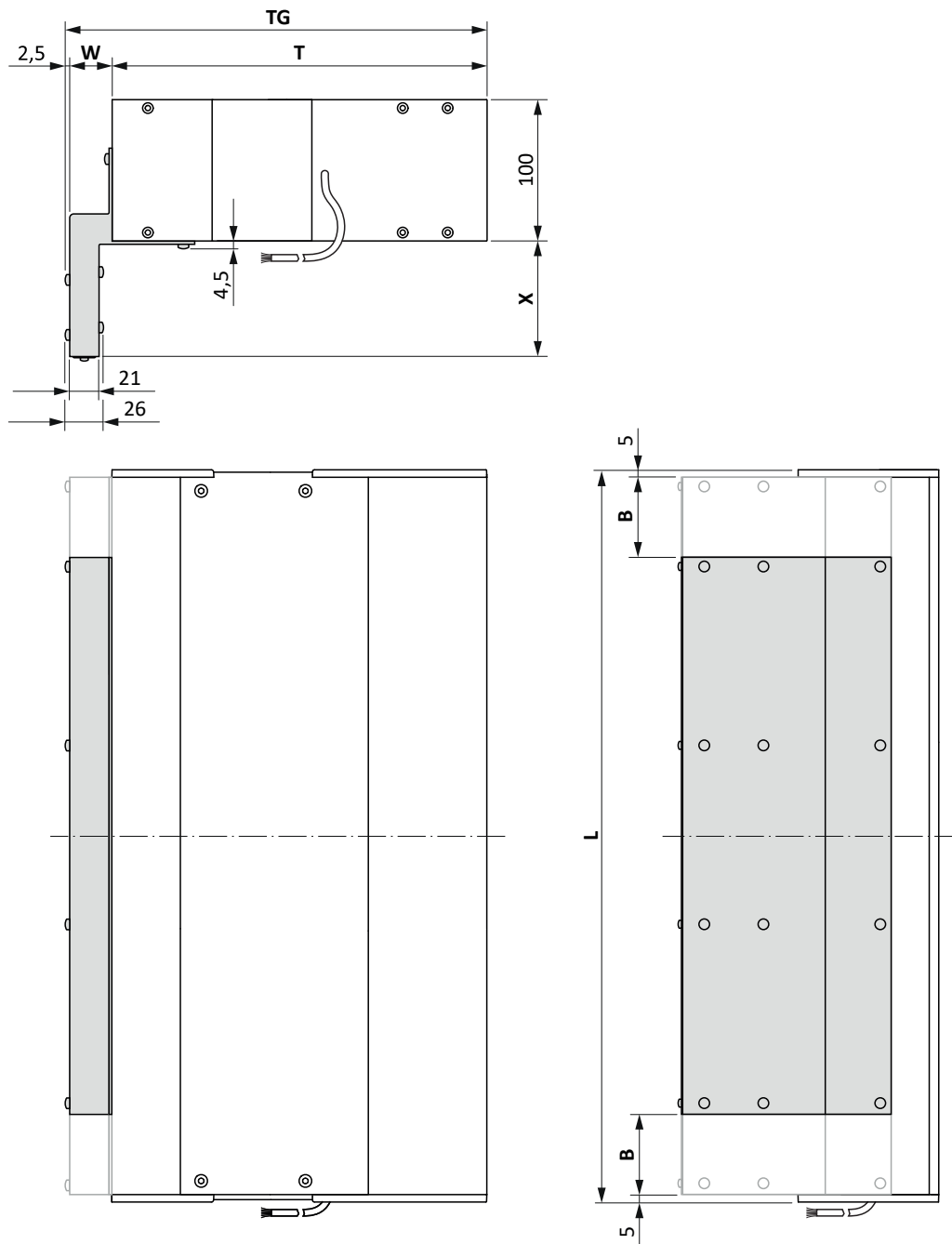

Measurements in mm

<b>B</b>	Dimension for indented duct	Can be ordered in 1 mm increments
<b>L</b>	Ventilator length	Can be ordered in 10 mm increments
<b>T</b>	Ventilator depth	Can be ordered in 1 mm increments
<b>TG</b>	Total depth	Ventilator depth <b>T</b> + depth of duct <b>W</b> + 2.5 mm
<b>W</b>	Depth of duct	Can be ordered in 1 mm increments
<b>X</b>	Height of duct	Can be ordered in 1 mm increments

Device type	Dimension L (mm)	Dimension D (mm)	Dimension W (mm) <sup>1</sup>	Dimension X (mm) <sup>1</sup>	Dimension B (mm)
A1	750 – 890	300 – 500	15 – 500	25 – 1085	0 – 65
	900 – 3000				0 – 145
	3010 – 6000				0
A2	1500 – 3000	300 – 500	15 – 500	25 – 1085	0 – 145
	3010 – 6000				0

<sup>1)</sup>  $W + X \leq 1100$

**2.9 Dimensions of wall duct aluminium**

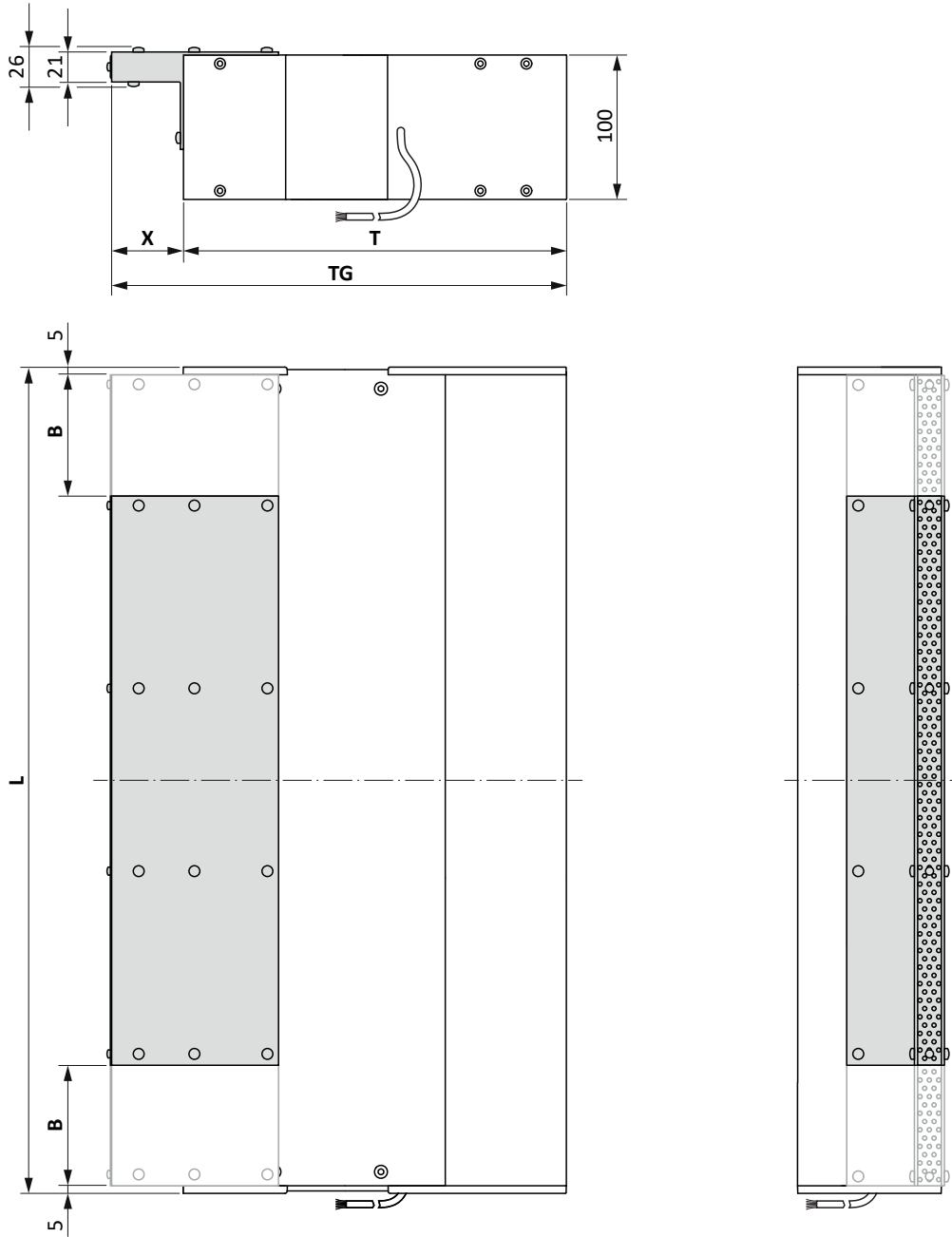

Measurements in mm

<b>B</b>	Dimension for indented duct	Can be ordered in 1 mm increments
<b>L</b>	Ventilator length	Can be ordered in 10 mm increments
<b>T</b>	Ventilator depth	Can be ordered in 1 mm increments
<b>TG</b>	Total depth	Ventilator depth <b>T</b> + <b>X</b>
<b>X</b>	Depth of duct	Can be ordered in 1 mm increments

Device type	Dimension L (mm)	Dimension D (mm)	Dimension X (mm)	Dimension B (mm)
A1	750 – 890	300 – 500	25 – 1100	0 – 65
	900 – 3000			0 – 145
	3010 – 6000			0
A2	1500 – 3000	300 – 500	25 – 1100	0 – 145
	3010 – 6000			0

**2.10 Dimensions of wall duct aluminium angled**

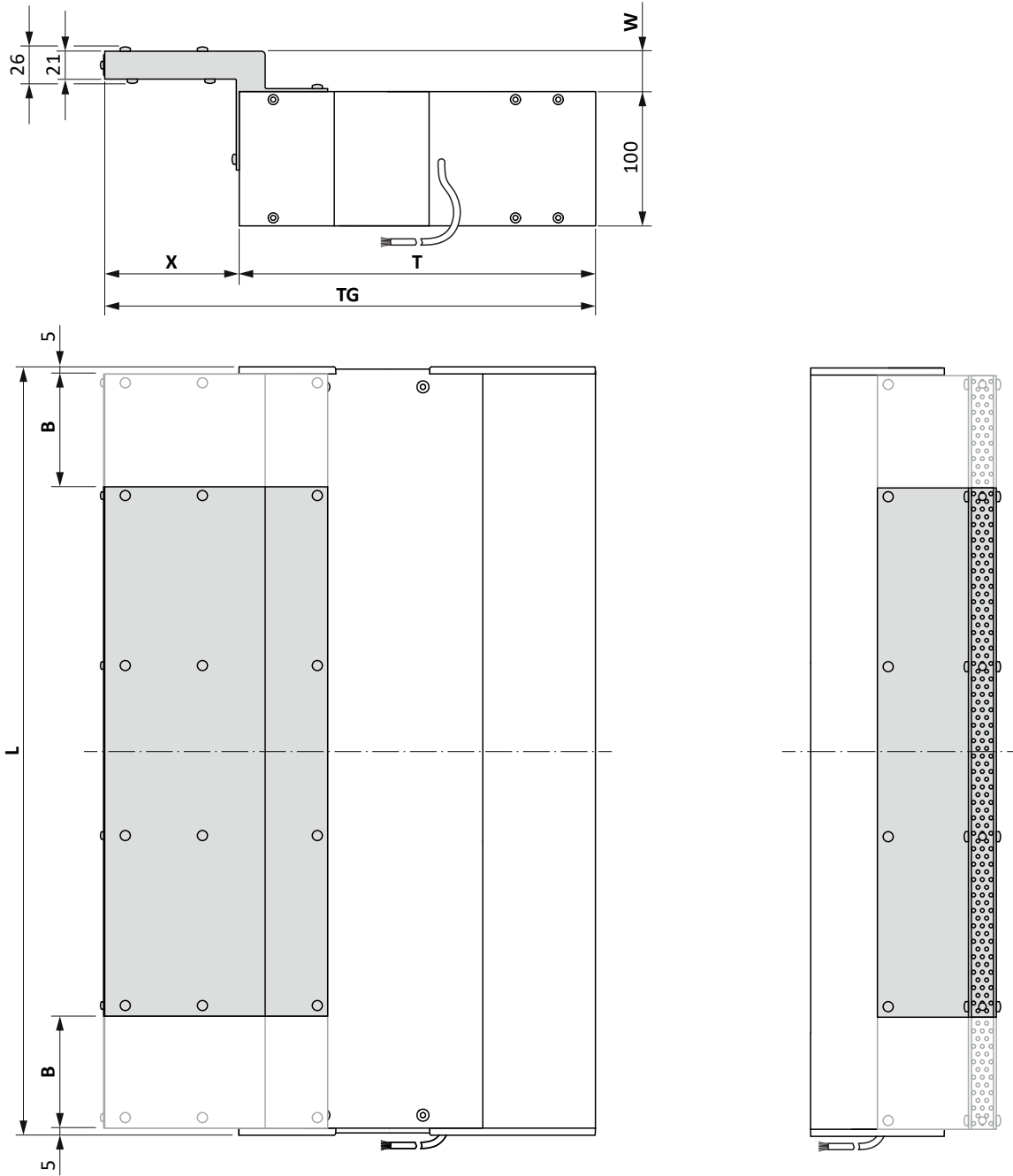

Measurements in mm

<b>B</b>	Dimension for indented duct	Can be ordered in 1 mm increments
<b>L</b>	Ventilator length	Can be ordered in 10 mm increments
<b>T</b>	Ventilator depth	Can be ordered in 1 mm increments
<b>TG</b>	Total depth	Ventilator depth <b>T</b> + <b>X</b>
<b>W</b>	Height of duct	Can be ordered in 1 mm increments
<b>X</b>	Depth of duct	Can be ordered in 1 mm increments

Device type	Dimension L (mm)	Dimension D (mm)	Dimension W (mm) <sup>1</sup>	Dimension X (mm) <sup>1</sup>	Dimension B (mm)
A1	750 – 890	300 – 500	15 – 500	25 – 1085	0 – 65
	900 – 3000				0 – 145
	3010 – 6000				0
A2	1500 – 3000	300 – 500	15 – 500	25 – 1085	0 – 145
	3010 – 6000				0

<sup>1)</sup>  $W + X \leq 1100$

### 3 Accessories

name	Description	Material number
Wall duct EPP	Wall duct EPP (incl. assembly material)	vL3490200-097010
Vent duct and lintel duct EPP	Vent duct and lintel duct EPP (incl. assembly material)	vL3490180-097010
Extension canal	Extension duct for extension of wall duct or vent duct and lintel duct	vL3490240-097010
Compensation piece vent duct and lintel duct	Compensation piece for vent duct and lintel duct EPP (incl. assembly material)	vL3490190-097010
PVC outer panel for wall duct EPP	PVC outer panel for wall duct EPP (incl. assembly material) in white (similar to RAL 9016)	vL3490210-004010
PVC outer panel for wall duct EPP	PVC outer panel for wall duct EPP (incl. assembly material) in black (similar to RAL 9005)	vL3490220-023010
Aluminium outer panel for wall duct EPP	Aluminium outer panel for wall duct EPP to cover the PVC outer panel	vL3490230-500010
PVC outer panel for vent duct and lintel duct EPP	PVC outer panel for vent duct and lintel duct EPP (incl. assembly material) in white (similar to RAL 9016)	vL3490160-004010
PVC outer panel for vent duct and lintel duct EPP	PVC outer panel for vent duct and lintel duct EPP (incl. assembly material) in black (similar to RAL 9005)	vL3490150-023010
Aluminium outer panel for vent duct and lintel duct EPP	Aluminium outer panel for vent duct and lintel duct EPP to cover the PVC outer panel	vL3490170-500010
Ventilation control unit	Ventilation control unit for external operation	vL7360010-004010
Sensor-based ventilation control unit	Ventilation control unit with integrated sensors for external operation	vL7360020-004010

## 4 Technical specifications

		AEROMAT VT A1	AEROMAT VT A2	AEROMAT VT A2 (CCFAT)
Ventilator length		750 mm	1500 mm	1500 mm
Ventilator depth		300 mm	300 mm	300 mm
Sound absorption $D_{n,e,w}$ in ventilation operation (measured according to DIN EN 10140-2)		57 dB	54 dB	54 dB
Air throughput	Blower level 1	10 m <sup>3</sup> /h	20 m <sup>3</sup> /h	20 m <sup>3</sup> /h
	Blower level 2	20 m <sup>3</sup> /h	40 m <sup>3</sup> /h	45 m <sup>3</sup> /h
	Blower level 3	30 m <sup>3</sup> /h	60 m <sup>3</sup> /h	60 m <sup>3</sup> /h
	Blower level 4	45 m <sup>3</sup> /h	90 m <sup>3</sup> /h	90 m <sup>3</sup> /h
	Blower level 5	60 m <sup>3</sup> /h	120 m <sup>3</sup> /h <sup>1</sup>	135 m <sup>3</sup> /h
Inherent noise $L_{pA}$ (measured according to DIN EN ISO 13141-8, sound pressure level with room insulation of 8 dB)	Blower level 1	15 dB (A)	17 dB (A)	17 dB (A)
	Blower level 2	16 dB (A)	19 dB (A)	20 dB (A)
	Blower level 3	20 dB (A)	21 dB (A)	21 dB (A)
	Blower level 4	28 dB (A)	31 dB (A)	31 dB (A)
	Blower level 5	35 dB (A)	37 dB (A)	40 dB (A)
Power consumption	Blower level 1	2 W	4 W	4 W
	Blower level 2	3 W	4 W	5 W
	Blower level 3	3 W	6 W	6 W
	Blower level 4	5 W	10 W	10 W
	Blower level 5	9 W	20 W	27 W
Supply voltage		230 V AC	230 V AC	230 V AC
Supply frequency		50 Hz	50 Hz	50 Hz
Operating voltage		24 V DC	24 V DC	24 V DC
Protection class		II	II	II
Max. permissible area load		1000 kg/m	1000 kg/m	1000 kg/m
Permissible operating temperature		-15 – +40 °C	-15 – +40 °C	-15 – +40 °C
Length of connecting cable		5 – 20 m	5 – 20 m	5 – 20 m

<sup>1</sup> Power level 135 m<sup>3</sup>/h optionally available (deviating inherent noise and power consumption).

Technical specifications measured without filter and without extension parts as well as with minimum ventilator length.